

Submittal

Split System Heat Pump

E4HL5030A1000A

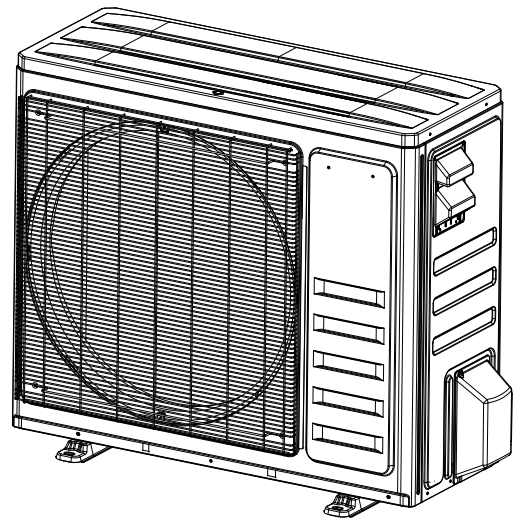

NOTE: "Graphics in this document are for representation only. Actual model may differ in appearance."

Outline Drawing

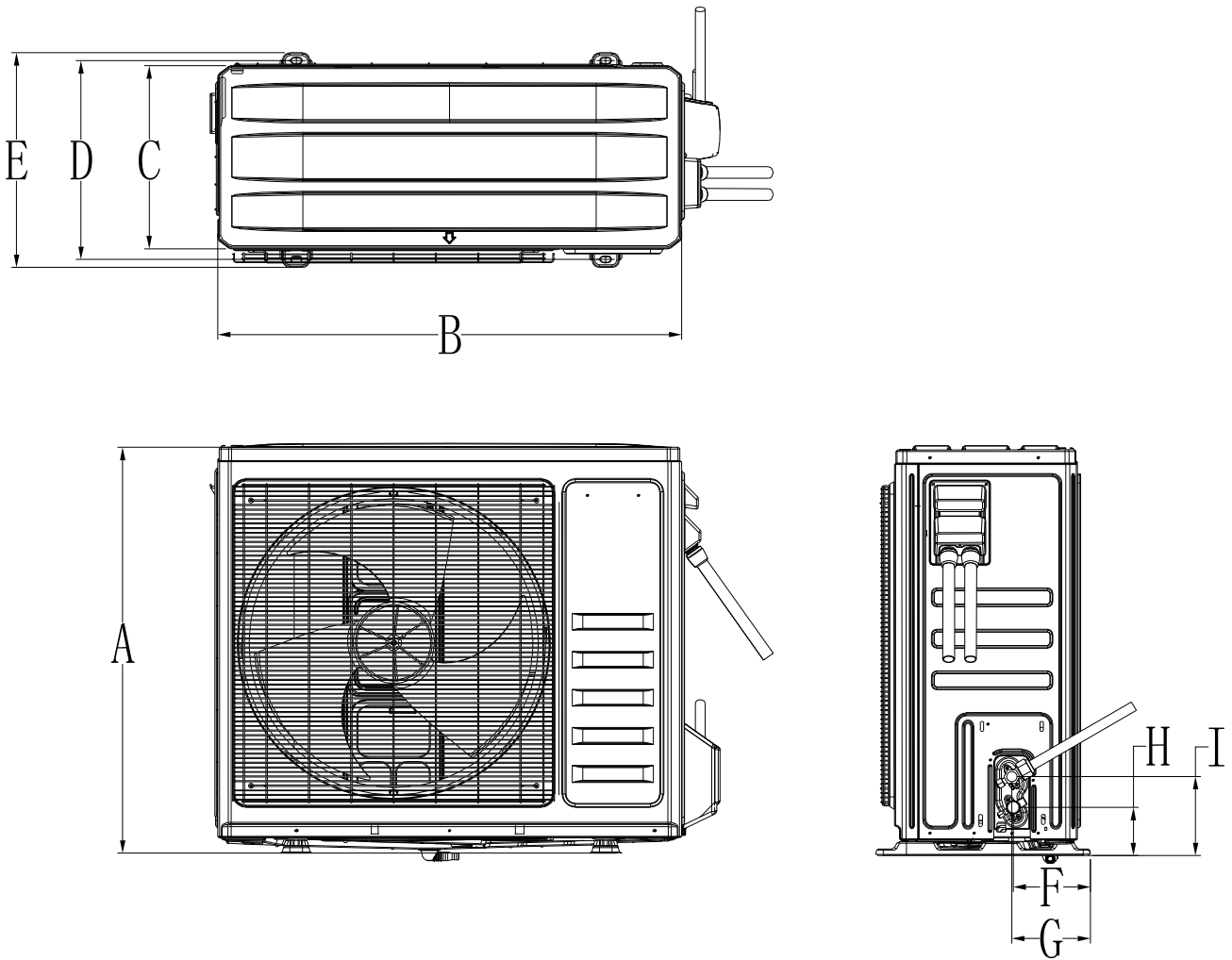

| Model | A | B | C | D | E | F | G | H | I |
|----------------|-------|-------|-------|-------|-------|------|------|------|------|
| E4HL5030A1000A | 31.35 | 35.83 | 14.13 | 15.36 | 16.59 | 5.97 | 6.07 | 3.71 | 6.09 |

All dimensions are in inches

NOTE: ALL DIMENSIONS ARE REFERENCE DIMENSIONS

| Model | A-Weighted Sound Power Level [dB(A)] | SOUND POWER LEVEL | | | | | | | |
|----------------|--------------------------------------|------------------------------|-------|-------|-------|--------|--------|--------|--------|
| | | Full Octave Sound Power [dB] | | | | | | | |
| | | 63Hz* | 125Hz | 250Hz | 500Hz | 1000Hz | 2000Hz | 4000Hz | 8000Hz |
| E4HL5030A1000A | 62 | 60 | 56 | 53 | 54 | 59 | 55 | 42 | 34 |

Note: Rated in accordance with AHRI Standard 270-2015 *For reference only.

Product Specifications

| | |
|--------------------------------|-------------------------|
| OUTDOOR UNIT (a) | E4HL5030A1000A |
| POWER CONNS. — V/PH/HZ (b) | 208/230/1/60 |
| MIN. CIR. AMPACITY | 22 |
| MAX. OVERCURRENT PROTECTION | 35 |
| COMPRESSOR | Rotary |
| NO. USED — NO. STAGES | 1-VARIABLE |
| VOLTS/PH/HZ | 208/230/1/60 |
| R.L. AMPS (c) | 15.8 |
| FACTORY INSTALLED | |
| START COMPONENTS (d) | NO |
| INSULATION/SOUND BLANKET | YES |
| COMPRESSOR HEAT | NO |
| OUTDOOR FAN | PROPELLER |
| DIA. (IN.) — NO. USED | 21-5/8"-1 |
| TYPE DRIVE — NO. SPEEDS | DIRECT — VARIABLE |
| NO. MOTORS — HP | 1-1/10 |
| CFM @ 0.0 IN. W.G. (e) | 2300 |
| MOTOR SPEED R.P.M. | 850 |
| VOLTS/PH/HZ | 208/230/1/60 |
| F.L. AMPS | 1.1 |
| OUTDOOR COIL — TYPE | PLATE FIN |
| ROWS — F.P.I. | 3-17 |
| FACE AREA (SQ. FT.) | 8.18 |
| TUBE SIZE (IN.) | 1/4" |
| REFRIGERANT CONTROL | ELEC. EXPANSION VALVE |
| REFRIGERANT | |
| LBS. — R-410A (O.D. UNIT) (f) | 7 LBS, 4 OZ |
| FACTORY SUPPLIED | YES |
| LINE SIZE — IN. O.D. GAS | 3/4" |
| LINE SIZE — IN. O.D. LIQ. | 3/8" |
| CHARGING SPECIFICATIONS | |
| SUBCOOLING | 5°F |
| DIMENSIONS | H x W x D |
| CRATED (IN.) | 40-1/4"×32-7/8"×18-7/8" |
| UNCRATED (IN.) | 35-3/4"×31-5/8"×14-1/8" |
| WEIGHT | |
| Shipping | 176 |
| Net (Lbs.) | 121 |

(a) Certified in accordance with the Air-Source Unitary Air-conditioner Equipment certification program, which is based on AHRI standard 210/240.

(b) Calculated in accordance with Natl. Elec. Codes. Use only HACR circuit breakers or fuses.

(c) This value shown for compressor RLA on the unit nameplate and on this specification sheet is used to compute minimum branch circuit ampacity and max. fuse size. The value shown is the branch circuit selection current.

(d) No means no start components.

(e) Standard Air — Dry Coil — Outdoor

(f) This value is approximate. For more precise value see unit nameplate.

Mechanical Specification Options

General

The outdoor condensing units are factory charged with the system charge required for the outdoor condensing unit, 24.6 feet of tested connecting line, and the smallest rated indoor evaporative coil match. This unit is designed to operate at outdoor ambient temperatures as high as 115°F. Cooling capacities are matched with a wide selection of air handlers and furnace coils that are AHRI certified. The unit is certified to UL 60335-2-40. Exterior is designed for outdoor application.

Casing

Unit is painted with a glossy corrosion resistant finish on all panels. Unit casing is constructed of heavy gauge, galvanized steel and painted with a weather-resistant powder paint finish. All panels are subjected to our 500 hour salt spray test.

Refrigerant Controls

Refrigeration system controls include condenser fan, compressor drive and low pressure switches.

Compressor

The compressor features external over temperature and pressure protection. Other features include: Centrifugal oil pump and low vibration and noise.

Condenser Coil

The outdoor coil provides low airflow resistance and efficient heat transfer. The coil is protected on all four sides by grilles and panels.

Low Ambient Cooling

As manufactured, this system has a cooling capacity to 5°F.

Trane - by Trane Technologies (NYSE: TT), a global innovator - creates comfortable, energy efficient indoor environments for commercial and residential applications. For more information, please visit trane.com or tranetechnologies.com.



The AHRI Certified mark indicates Trane U.S. Inc. participation in the AHRI Certification program. For verification of individual certified products, go to ahridirectory.org.

Trane has a policy of continuous data improvement and it reserves the right to change design and specifications without notice. We are committed to using environmentally conscious print practices.